

SUSPENSION KIT FOR BOURNE MULTI-INSTALLATION DALI EMERGENCY EXIT BLADE

NET-51-10-79



Features & Benefits

- Allows for easy hanging from ceilings, making it suitable for various installation environments where recessed mounting may not be practical
- Specifically designed to work seamlessly with DALI emergency exit signs
- Ensures that emergency exit signage is prominently displayed

Key Data

Dimensions

Max. 1500 x 40 x 200mm

Warranty

5 Years (Registration Required)

NET LED Lighting

Buckingway Business Park, 300 Anderson Road,
Swavesey, Cambridge, CB24 4UQ

T: 01223 851505 | sales@netled.co.uk | www.netled.co.uk



ORDER BY 6PM

FOR NEXT DAY DELIVERY

Technical Specifications

Electrical Class	1
Operating Temp.	0°C to +45°C
Manufacturer	Sealite Co. Ltd.
Product Fixing Method	Surface Mounted
Housing Colour	White
Housing Material	Steel

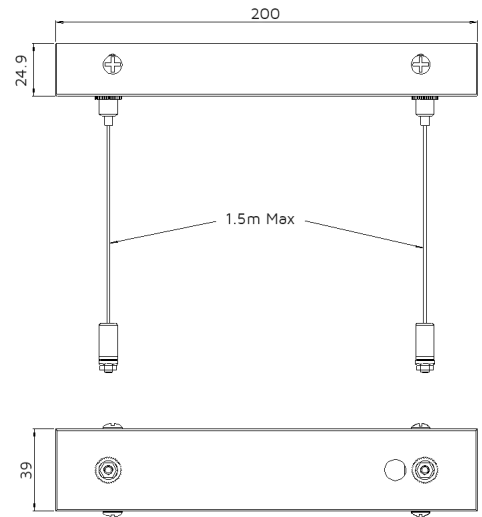

Other Options

Description	
NET-51-10-79	Suspension Kit for Bourne Multi-Installation DALI Emergency EXIT Blade

NET LED Lighting

Buckingham Business Park, 300 Anderson Road,
Swavesey, Cambridge, CB24 4UQ

T: 01223 851505 | sales@netled.co.uk | www.netled.co.uk



ORDER BY 6PM
FOR NEXT DAY DELIVERY