

## WALL MOUNTING KIT FOR MARCH LINEAR LIGHT BARS

NET-43-11-46

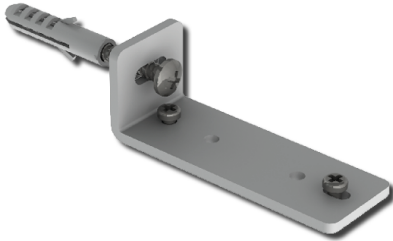

### Features & Benefits

- Provides a sturdy and reliable solution for mounting linears directly onto walls
- Quick and hassle-free setup
- Perfect for areas where ceiling or suspended installations aren't practical

#### NET LED Lighting

Buckingway Business Park, 300 Anderson Road,  
Swavesey, Cambridge, CB24 4UQ

T: 01223 851505 | [sales@netled.co.uk](mailto:sales@netled.co.uk) | [www.netled.co.uk](http://www.netled.co.uk)



**ORDER BY 6PM**  
FOR NEXT DAY DELIVERY

## Technical Specifications

Manufacturer

Sochii Lighting

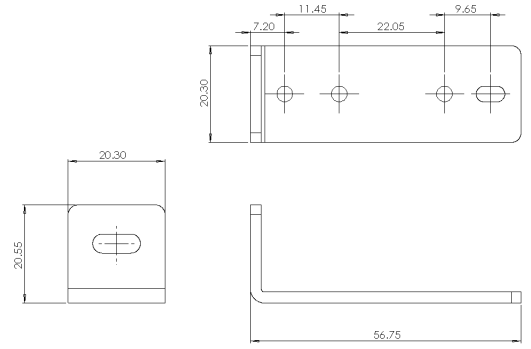

## Other Options

Description	
NET-43-11-46	Wall Mounting Kit for March Linear Light Bars

### NET LED Lighting

Buckingway Business Park, 300 Anderson Road,  
Swavesey, Cambridge, CB24 4UQ

T: 01223 851505 | [sales@netled.co.uk](mailto:sales@netled.co.uk) | [www.netled.co.uk](http://www.netled.co.uk)



**ORDER BY 6PM**  
FOR NEXT DAY DELIVERY