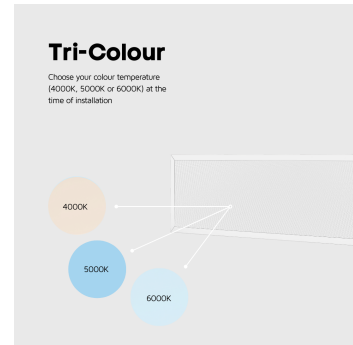
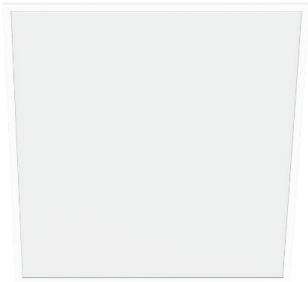

ASHLEY BACKLIT PANEL UGR<19 TRI-COLOUR TP(A) 500X500 30W DIMMABLE

NET-43-03-84

Features & Benefits

- Tridonic one4all Dimming - DALI 1 & 2 or switchDIM (Push)
- Low glare diffuser with UGR rating <19
- TP(a) flammability-rated diffuser
- Selectable 3000K, 4000K or 6000K colour temperature
- Flicker-free driver
- Backlit for a uniform light distribution

Key Data

Power	30W
Luminous Flux	3600lm/3900lm/3600lm
Colour Temperature	3000K/4000K/6000K
IP Rating	IP20
Dimensions	495 x 495 x 32mm
Warranty	5 Years (Registration Required)

Compatible Accessories

NET-46-16-02	Universal LED Panel Suspension Kit
NET-39-16-03	Burgess Z Clips
NET-39-16-05	Burgess Adjustable Z Clips

NET LED Lighting

 Buckingham Business Park, 300 Anderson Road,
 Swavesey, Cambridge, CB24 4UQ

T: 01223 851505 | sales@netled.co.uk | www.netled.co.uk

ORDER BY 6PM
 FOR NEXT DAY DELIVERY

Technical Specifications

Input Voltage (AC)	220-240V
Power Factor	>0.9
Luminaire Efficacy	130lm/W
LED Manufacturer	Hongliitronic
LED Type	SMD 2835
Driver Manufacturer	Tridonic
Driver Output Voltage (DC)	30-42V
Total Circuit Power (W)	30W
Electrical Class	2
Colour Rendering	>80 CRI
Lamp Viewing Angle	120°
Dimmable	Yes
Flicker-Free	Yes
Operating Temp.	-15°C to +45°C
Lifespan LM80	50,000 Hours
Diffuser Flammability Rating	TP(a)
UGR Rating	Less than 19
Diffuser/LGP Material	PS
Manufacturer	Sochii Lighting
Frame Colour	White
Dimming Input Type	Tridonic one4all Dimming - DALI 1 & 2 and switchDIM (Push)

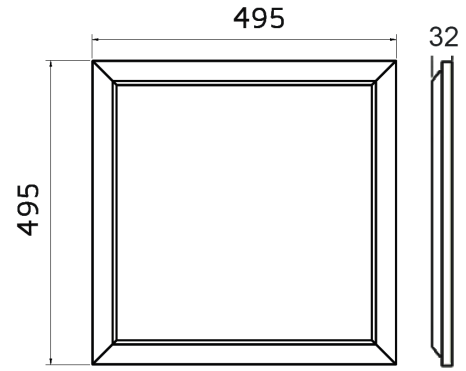

All units are in mm

Other Options

Description	
NET-43-03-82	Ashley Backlit Panel UGR<19 Tri-Colour TP(a) 500x500 30W Standard
NET-43-03-83	Ashley Backlit Panel UGR<19 Tri-Colour TP(a) 500x500 30W Emergency/Self Test
NET-43-03-84	Ashley Backlit Panel UGR<19 Tri-Colour TP(a) 500x500 30W Dimmable one4all
NET-43-03-85	Ashley Backlit Panel UGR<19 Tri-Colour TP(a) 500x500 30W Dimmable Emergency/Self Test
NET-43-03-86	Ashley Backlit Panel UGR<19 Tri-Colour TP(a) 500x500 30W Dimmable DALI Emergency

NET LED Lighting

Buckingham Business Park, 300 Anderson Road,
Swavesey, Cambridge, CB24 4UQ



ORDER BY 6PM
FOR NEXT DAY DELIVERY

T: 01223 851505 | sales@netled.co.uk | www.netled.co.uk

Up to
140
lm/W

BACKLIT DESIGN

Reduce the number of fittings needed with its higher light output and lumen per watt ratio

SELECTABLE COLOUR TEMPERATURE

Choose your colour temperature 4000K, 5000K or 6000K

4K

5K

6K

WIRELESS CONTROL

Control the panel remotely via smartphone or tablet with its Bluetooth Dimmable Driver

Bluetooth options only

TRIDONIC DIMMABLE DRIVER

Customise lighting levels and reduce energy consumption

Dimmable options only

MANUAL OR SELF TEST EMERGENCY SELECTABLE

Choose between manual emergency or self test emergency at the time of installation

Emergency options only

LOW GLARE UGR<19 AND TP(A) FLAMMABILITY RATED DIFFUSER

Reduce headaches and comply with Building Regulations

