

NEWTON WHITE POLYCARBONATE BULKHEAD MULTI-WATTAGE TRI-COLOUR IP65

NET-33-06-52

Features & Benefits

- Choose between 12W, 14W, 16W or 18W at the time of installation
- Selectable colour temperature 3000K, 4000K or 5500K
- Shatterproof polycarbonate diffuser
- Push connector for easy installation
- IP65 rated housing

Key Data

Power	12W/14W/16W/18W
Luminous Flux	1200lm/1400lm/1600lm/1800lm
Colour Temperature	3000K/4000K/5500K
IP Rating	IP65
IK Rating	IK10
Dimensions	Ø282 x 86.5mm
Warranty	3 Years

Compatible Accessories

NET-51-04-59	Photocell Kit for Outdoor Lighting
--------------	------------------------------------

NET LED Lighting

 Buckingham Business Park, 300 Anderson Road,
 Swavesey, Cambridge, CB24 4UQ

T: 01223 851505 | sales@netled.co.uk | www.netled.co.uk

ORDER BY 6PM
 FOR NEXT DAY DELIVERY

Technical Specifications

Input Voltage (AC)	220-240V
Power Factor	>0.9
Luminaire Efficacy	100lm/w
LED Manufacturer	Hongliitronic
LED Type	SMD 2835
No. of LEDs	52
Driver Manufacturer	Tridonic
Driver Output Voltage (DC)	36-42V
Total Circuit Power (W)	12W/14W/16W/18W
Electrical Class	1
Colour Rendering	>80 CRI
Lamp Viewing Angle	115°
Dimmable	No
Operating Temp.	-15°C to +45°C
Lifespan LM80	35,000 Hours
UGR Rating	More than 19
Weight	1.04Kg
Manufacturer	NET LED Lighting
Fire Rating	V0
Housing Colour	White
Housing Material	Polycarbonate
Diffuser Material	Polycarbonate

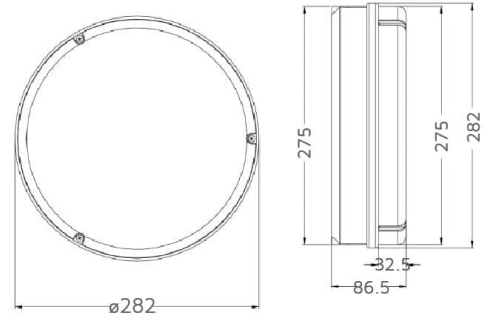

Other Options

Description	
NET-33-06-52	Newton White Polycarbonate Bulkhead Multi-Wattage Tri-Colour IP65 Standard
NET-33-06-54	Newton White Polycarbonate Bulkhead Multi-Wattage Tri-Colour IP65 Emergency/Self Test
NET-33-06-56	Newton White Polycarbonate Bulkhead Tri-Colour IP65 16W Microwave Sensor
NET-33-06-58	Newton White Polycarbonate Bulkhead Tri-Colour IP65 16W Microwave Sensor Emergency/Self Test
NET-33-06-76	Newton White Polycarbonate Bulkhead Multi-Wattage Tri-Colour IP65 Photocell
NET-33-06-77	Newton White Polycarbonate Bulkhead Multi-Wattage Tri-Colour IP65 Photocell Emergency/Self Test

NET LED Lighting

Buckingham Business Park, 300 Anderson Road,
Swavesey, Cambridge, CB24 4UQ



ORDER BY 6PM
FOR NEXT DAY DELIVERY

3K

4K

5.5K

INTEGRAL MICROWAVE SENSOR

Featuring a 0 or 10% Standby Mode, 2-10m detection range and 5sec to 10min hold time

Microwave Sensor options only

SELECTABLE COLOUR TEMPERATURE

Choose your colour temperature 3000K, 4000K or 5500K

SHATTERPROOF POLYCARBONATE DIFFUSER

Designed to prevent the diffuser shattering into small, indistinct pieces

NEW

MANUAL OR SELF TEST EMERGENCY SELECTABLE

Choose between manual emergency or self test emergency at the time of installation

Emergency options only

DUSK TO DAWN FUNCTION

Detects ambient light levels and adjusts the light accordingly

Photocell options only

PUSH CONNECTOR

Reduce installation time with easy-to-use push fit terminals

REAR OR SIDE CABLE ENTRY

Protect your wiring from harsh weather and possible tampering

IP65 RATED HOUSING

Protect your bulkhead from water and dust