

**DUXFORD BULKHEAD 4000K IP65 16W MICROWAVE SENSOR EMERGENCY/SELF TEST**

NET-33-06-46



**Features & Benefits**

- Daylight threshold
- Dusk to dawn function
- Off during the day, 10% output at night and 100% with Motion Sensor
- Detection range from 2m to 10m
- Selectable 3000K, 4000K or 5500K colour temperature
- IP65 rated housing

**Key Data**

<b>Power</b>	16W
<b>Luminous Flux</b>	1600lm
<b>Colour Temperature</b>	4000K
<b>IP Rating</b>	IP65
<b>Dimensions</b>	Ø325 x 110mm
<b>Warranty</b>	3 Years

**Compatible Accessories**

NET-51-04-59	Photocell Kit for Outdoor Lighting
--------------	------------------------------------

**NET LED Lighting**

Buckingham Business Park, 300 Anderson Road,  
Swavesey, Cambridge, CB24 4UQ

T: 01223 851505 | sales@netled.co.uk | www.netled.co.uk



**ORDER BY 6PM**  
FOR NEXT DAY DELIVERY

## Technical Specifications

Input Voltage (AC)	220-240V
Power Factor	>0.9
Luminaire Efficacy	100lm/W
LED Manufacturer	Jingrui
LED Type	SMD 2835
No. of LEDs	52
Driver Manufacturer	Merrytek
Driver Output Voltage (DC)	36-42V
Total Circuit Power (W)	16W
Electrical Class	1
Colour Rendering	>80 CRI
Lamp Viewing Angle	115°
Dimmable	No
Operating Temp.	0°C to +45°C
Lifespan LM80	35,000 Hours
UGR Rating	More than 19
Weight	1.13Kg
Manufacturer	NET LED Lighting
Fire Rating	V2
Luminous Flux Factor	5%
Self Test	Selectable
Housing Colour	White
Housing Material	Polycarbonate
Battery Pack	Li-on 3.7V
Diffuser Material	Polycarbonate
Emergency Kit	1 Year Warranty
Emergency Operation	>3H
Emergency Pack	Streamer
Sensor IP Rating	IP20
Standby Dimming Level	0% / 10%
Corridor Function	Yes

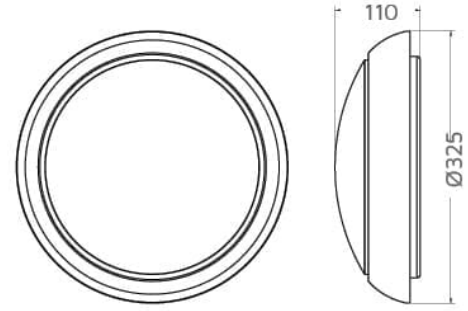

## Other Options

Description	
NET-33-06-40	Duxford Bulkhead Multi-Wattage 4000K IP65 Standard
NET-33-06-42	Duxford Bulkhead Multi-Wattage 4000K IP65 Emergency/Self Test
NET-33-06-44	Duxford Bulkhead 4000K IP65 16W Microwave Sensor
NET-33-06-46	Duxford Bulkhead 4000K IP65 16W Microwave Sensor Emergency/Self Test

## NET LED Lighting

Buckingham Business Park, 300 Anderson Road,  
Swavesey, Cambridge, CB24 4UQ



**ORDER BY 6PM**  
FOR NEXT DAY DELIVERY

## SHATTERPROOF POLYCARBONATE DIFFUSER

Prevents the fitting from breaking into multiple small pieces

## IP65 RATED HOUSING

Protect your bulkhead from water and dust

3K

4K

5.5K

## SELECTABLE COLOUR TEMPERATURE

Choose your colour temperature  
3000K, 4000K or 5500K

**NEW**

## MULTI WATTAGE DRIVER

Choose between 12W, 14W,  
16W or 18W at the time  
of installation

*NOT on Microwave Sensor options*

## INTEGRAL MICROWAVE SENSOR

Featuring a 0 or 10% Standby  
Mode, 2-10m detection range  
and 5sec to 10min hold time

*Microwave Sensor options only*

**NEW**

## MANUAL OR SELF TEST EMERGENCY SELECTABLE

Choose between manual  
emergency or self test  
emergency at the time  
of installation

*Emergency options only*

## DUSK TO DAWN FUNCTION

Detects ambient light levels  
and adjusts the light accordingly

*Photocell options only*

## PUSH CONNECTOR

Reduce installation time with  
easy-to-use push fit terminals



## SUITABLE FOR BESA BOX INSTALLATION

Save time on site with  
pre-made cable entry points