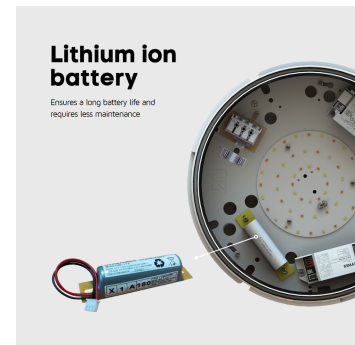

DUXFORD BULKHEAD MULTI-WATTAGE 4000K IP65 EMERGENCY/SELF TEST

NET-33-06-42

Features & Benefits

- Manual or self test selectable emergency operation
- Single colour temperature 4000K
- IP65 rated housing
- Shatterproof all-polycarbonate diffuser
- Raised mounting plate
- 3 rear entry positions

Key Data

Power	12W/14W/16W/18W
Luminous Flux	1200lm/1400lm/1600lm/1800lm
Colour Temperature	4000K
IP Rating	IP65
Dimensions	Ø325 x 110mm
Warranty	3 Years

Compatible Accessories

NET-51-04-59	Photocell Kit for Outdoor Lighting
--------------	------------------------------------

NET LED Lighting

 Buckingham Business Park, 300 Anderson Road,
 Swavesey, Cambridge, CB24 4UQ

T: 01223 851505 | sales@netled.co.uk | www.netled.co.uk

ORDER BY 6PM
 FOR NEXT DAY DELIVERY

Technical Specifications

Input Voltage (AC)	220-240V
Power Factor	>0.9
Luminaire Efficacy	100lm/w
LED Manufacturer	Jingrui
LED Type	SMD 2835
No. of LEDs	52
Driver Manufacturer	Tridonic
Driver Output Voltage (DC)	36-42V
Total Circuit Power (W)	12W/14W/16W/18W
Electrical Class	1
Colour Rendering	>80 CRI
Lamp Viewing Angle	115°
Dimmable	No
Operating Temp.	0°C to +45°C
Lifespan LM80	35,000 Hours
UGR Rating	More than 19
Weight	1.13Kg
Manufacturer	NET LED Lighting
Fire Rating	V2
Luminous Flux Factor	5%
Self Test	Selectable
Housing Colour	White
Housing Material	Polycarbonate
Battery Pack	Li-on 3.7V
Diffuser Material	Polycarbonate
Emergency Kit	1 Year Warranty
Emergency Operation	>3H
Emergency Pack	Streamer

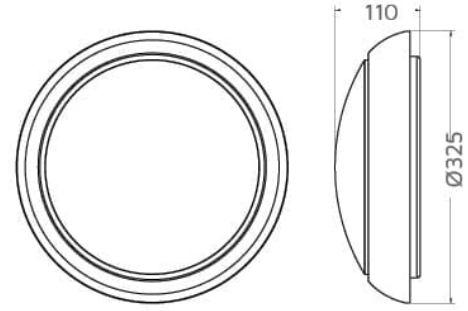

Other Options

Description	
NET-33-06-40	Duxford Bulkhead Multi-Wattage 4000K IP65 Standard
NET-33-06-42	Duxford Bulkhead Multi-Wattage 4000K IP65 Emergency/Self Test
NET-33-06-44	Duxford Bulkhead 4000K IP65 16W Microwave Sensor
NET-33-06-46	Duxford Bulkhead 4000K IP65 16W Microwave Sensor Emergency/Self Test

NET LED Lighting

Buckingham Business Park, 300 Anderson Road,
Swavesey, Cambridge, CB24 4UQ



ORDER BY 6PM
FOR NEXT DAY DELIVERY

SHATTERPROOF POLYCARBONATE DIFFUSER

Prevents the fitting from breaking into multiple small pieces

IP65 RATED HOUSING

Protect your bulkhead from water and dust

3K

4K

5.5K

SELECTABLE COLOUR TEMPERATURE

Choose your colour temperature
3000K, 4000K or 5500K

NEW

MULTI WATTAGE DRIVER

Choose between 12W, 14W,
16W or 18W at the time
of installation

NOT on Microwave Sensor options

INTEGRAL MICROWAVE SENSOR

Featuring a 0 or 10% Standby
Mode, 2-10m detection range
and 5sec to 10min hold time

Microwave Sensor options only

NEW

MANUAL OR SELF TEST EMERGENCY SELECTABLE

Choose between manual
emergency or self test
emergency at the time
of installation

Emergency options only

DUSK TO DAWN FUNCTION

Detects ambient light levels
and adjusts the light accordingly

Photocell options only

PUSH CONNECTOR

Reduce installation time with
easy-to-use push fit terminals



SUITABLE FOR BESA BOX INSTALLATION

Save time on site with
pre-made cable entry points