

TWIN PIVOT BRACKET

NET-23-16-67

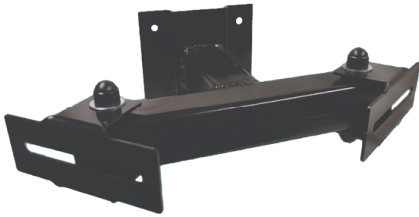

TWIN

**NET LED Lighting**

Buckingway Business Park, 300 Anderson Road,  
Swavesey, Cambridge, CB24 4UQ

T: 01223 851505 | [sales@netled.co.uk](mailto:sales@netled.co.uk) | [www.netled.co.uk](http://www.netled.co.uk)



**ORDER BY 6PM**  
FOR NEXT DAY DELIVERY

## Technical Specifications

Weight	2.9Kg
Depth	410mm
Mounting Plate	150 x 65mm
Back Plate	150 x 150mm
Fixing Size	M8

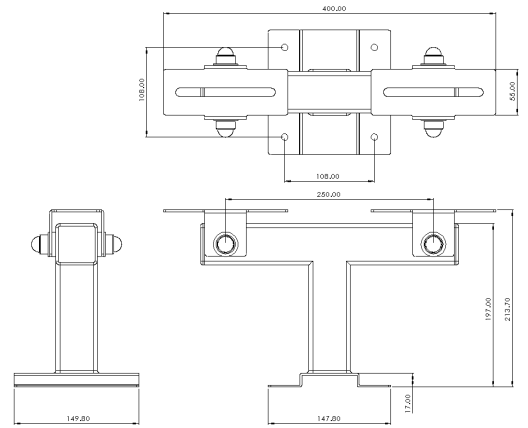

## Other Options

Description	
NET-23-16-65	Single Pivot Bracket
NET-23-16-67	Twin Pivot Bracket

## NET LED Lighting

Buckingham Business Park, 300 Anderson Road,  
Swavesey, Cambridge, CB24 4UQ



**ORDER BY 6PM**  
FOR NEXT DAY DELIVERY

T: 01223 851505 | [sales@netled.co.uk](mailto:sales@netled.co.uk) | [www.netled.co.uk](http://www.netled.co.uk)