

Safety Information

> All electrical work must be undertaken by a qualified contractor to ensure compliance with latest edition BS7671 and IEE/IET wiring regulations.

> Before installing a Bulkhead or doing any maintenance, ensure power supply is turned off at the circuit breaker or fuse box.

> This product is designed for permanent connection to fixed wiring; the circuit should be protected with the appropriate MCB or fuse.

Environment

> Please DO NOT dispose of electrical items or packaging as unsorted waste. Use the recycling facilities provided by your local authorities.

PRODUCT DIMENSIONS

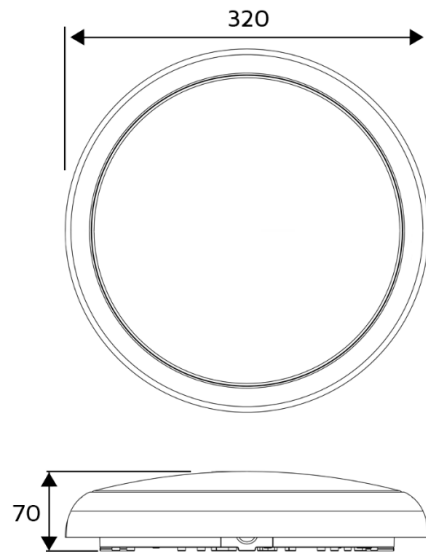

All units are in mm

Important Warranty Information

The LED Bulkhead has a 3 Year Warranty. The registrant must provide the product part number and date of manufacture, which can be found on the label attached to the Luminaire housing along with the original invoice. The Battery has a 1 Year Warranty.



Certificate No. FS 590684



Certificate No. EMS 590685

NET LED Lighting
Buckingham Business Park
300 Anderson Road
Cambridge
CB24 4UQ
sales@netled.co.uk
www.netled.co.uk

Technical Helpline: 01223 851505
Email: support@netled.co.uk

www.netled.co.uk/downloads

Distributed by



SHELFORD LED BULKHEAD INSTALLATION GUIDE

Part Number	Description
NET-41-06-02	Tri-colour - Standard
NET-41-06-04	Tri-colour - Emergency
NET-41-06-06	Tri-colour - Motion Sensor
NET-41-06-08	Tri-colour - Motion Sensor Emergency



SUPPLY/EARTH CLASS

220-240V AC 50/60 Hz

Fig.1 Mains Input Termination

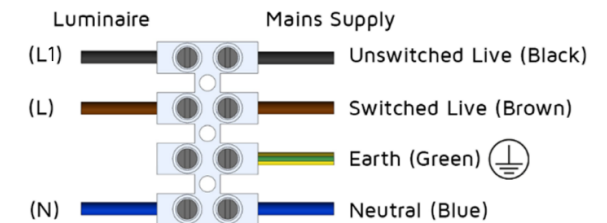

Installation procedure: Carefully read the installation instructions and ensure the mains supply is isolated before installation. Please read the safety information overleaf before carrying out any installation. Please retain this leaflet for future reference.

Bulkhead installation:



Replaceable (LED only) light source by professional



Replaceable control gear by professional

Step 1: Unclip the Outer Ring. Then remove the Diffuser by rotating it anti-clockwise.

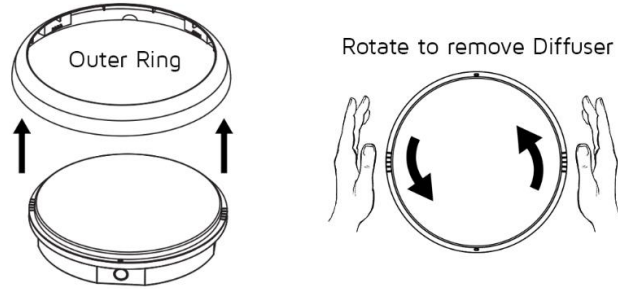

Step 2: Press the centre securing clips inward to release the LED Gear Tray. Disconnect the Gear Tray connector.

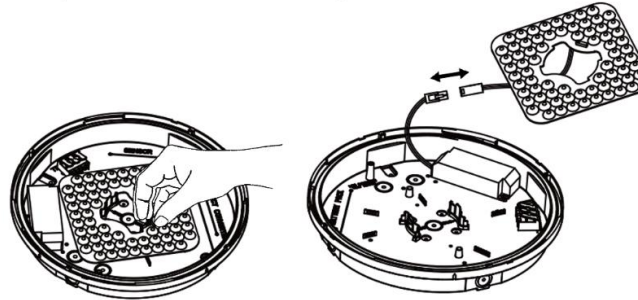

Step 3: Select the required cable entry point (Side entry or Rear Entry). Ensure the correct cable protection is attached depending on the entrypoint, and use an appropriate gland to maintain the IP65 seal.

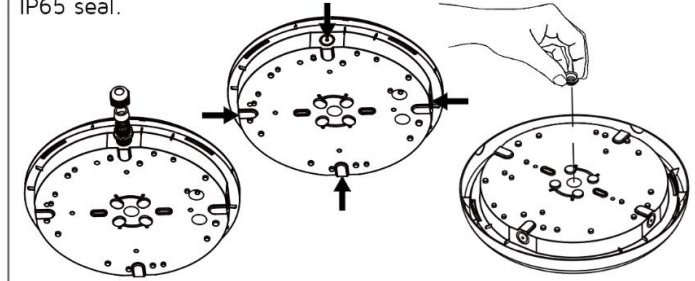

Step 4: Install the Bulkhead Base using the included fixing screws.

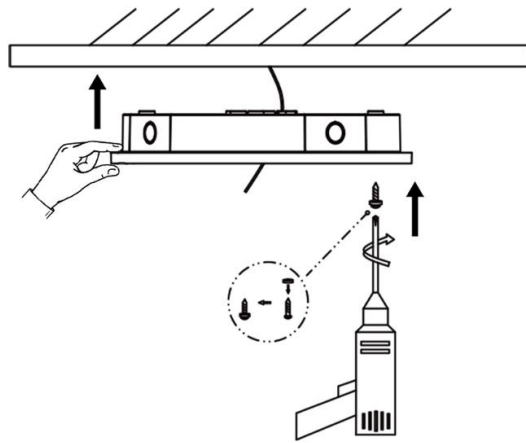

Step 5: Wire the Gear Tray as per the diagram below.

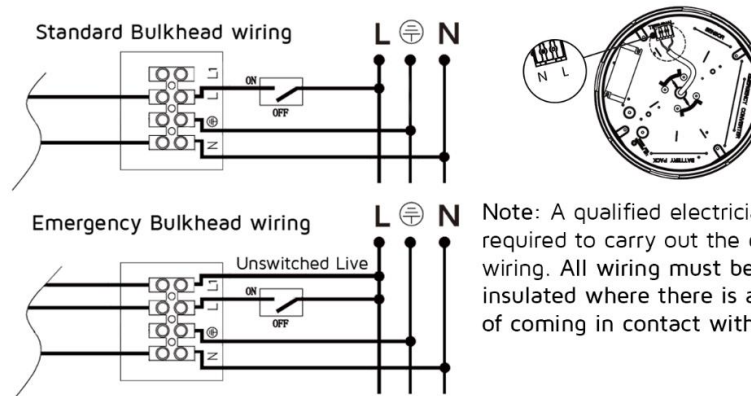

Emergency battery information



If the battery no longer charges, the battery will need to be changed as it no longer meets the rated duration of operation after the corresponding recharge period.

Important Battery Warranty information

The Battery has a 1 Year Warranty. To claim, you must provide the product part number and date of manufacture, which can be found on the label attached to the Luminaire housing along with the original purchase invoice.

Step 6: Connect the LED Gear Tray and LED Driver connectors. Then attach the LED Gear Tray Bulkhead Base. Select the required colour temperature and LED driver power output.

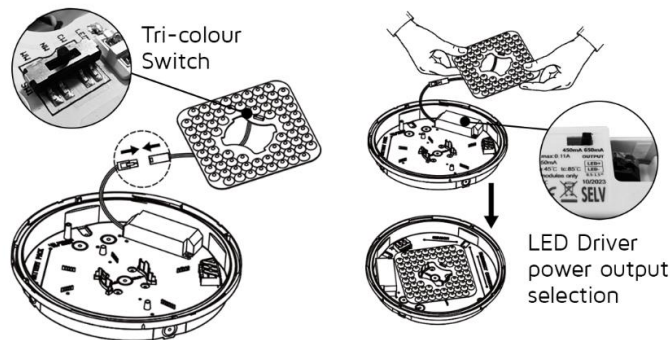

Step 7: Attach the Diffuser to the Housing Base, then rotate clockwise to lock in position and align fixing holes for anti-tamper screws. Install the 2x diffuser anti-tamper screws provided.

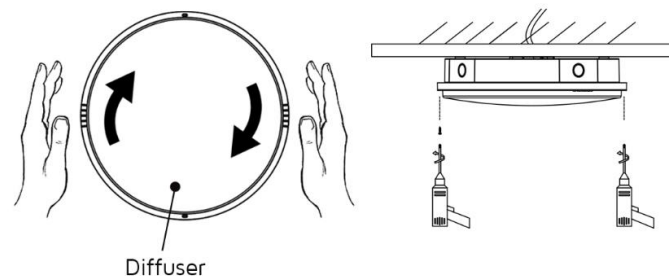

Step 8: Attach the Outer Ring to complete the installation.

